

FLOW DIVIDER Type DTP

- NS 6, 10
- to 350 bar
- to 70 l/min
- Dividing and combining of flow independent of pressure
- Dividing and combining ratio: 50 % : 50 %
- Direct in-line mounting
- Threaded connection to ISO 9974, ISO 1179

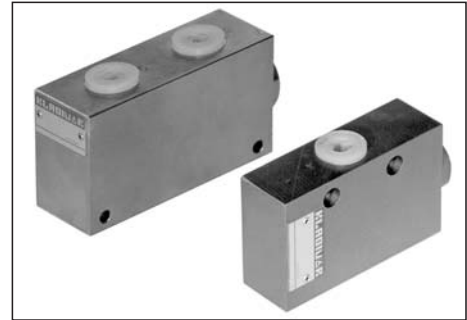

DTP-10, DTP-6

Description of operation

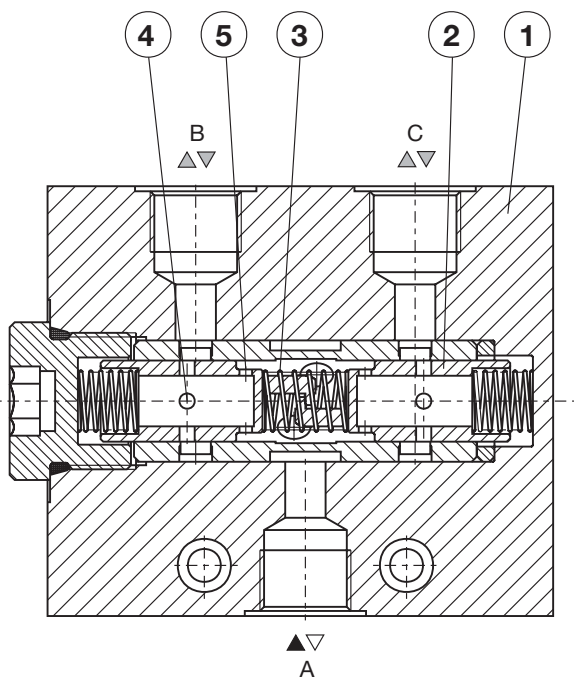

Symbol

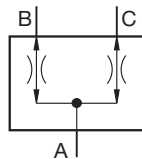

The flow divider DTP has two function, dividing and combining of fluid flow. The regulator divides the fluid flow in the direction from A to B and C, and combines flows in the direction from B and C to A. The dividing / combining ratio is 50 % : 50 %, independent of pressure in respective pipeline, B or C.

The regulator consists of a housing (1), two dividing spools (2) and three weak springs (3).

Division of flow: The fluid flow in the direction from A to B and C. The flow in chamber A is divided and flows through the orifices (5) with constant cross-section and throttles (4) into chambers B and C. The pressure drop through the orifices (5) depends on the pressure load. The increase of flow towards one of both chambers provokes increased pressure drop through the orifices. The pressure drop generates the pressure force which shifts both spools (2). Consequently, the throttles (4) are reduced, and the pressure drop of fluid through the throttles increases. The spools keep on moving until the pressure drops through the orifices (5) are balanced. Consequently, both fluid flows are balanced, too.

Combining of flows: The oil flow in the direction from B and C to A. The operation is identical as at dividing of flow. The divider combines both flows in the ratio 50 % to 50 %.

The principle of operation depends on the pressure drop, which again depends on the fluid flow. For this reason the divider functions properly only within the defined flow range. Limitation of maximal flow - rate of pressure drop, limitation of minimal pressure - dividing and combining accuracy.

Technical data

		DTP-6-20	DTP-6-35	DTP-6-50	DTP-10-70
Min. flow rate	l/min	8	12	16	35
Max. flow rate	l/min	20	35	50	70
Max. pressure range	bar	350			
Dividing	%	50 : 50			
Flow dividing accuracy	%	±5			
Oil temperature range	°C	-20 to +70			
Viscosity range	mm ² /s	15 to 380			
Filtration	NAS 1638	8			
Mass	kg	1,7	1,7	1,7	2,65

Ordering code

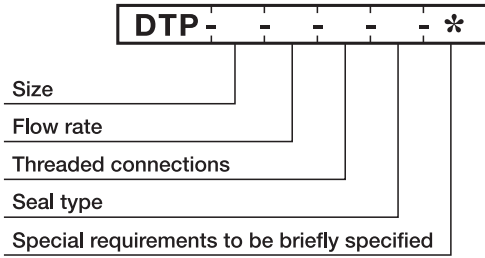

Size

Nominal size 6 = 6
 Nominal size 10 = 10

Flow rate

DTP-6 8 - 20 l/min = 20
 12 - 35 l/min = 35
 16 - 50 l/min = 50

DTP-10 35 - 70 l/min = 70

Threaded connections

DTP-6 M 18x1,5 = no desig.
 G 3/8 = G 3/8

DTP-10 M22x1,5 = M 22
 G 1/2 = G 1/2

Seal type

NBR seals for mineral oil HL, HLP, to DIN 51524 = no desig.
 FPM seals for HETG, HEES, HEPG to VDMA 24568 = E
 and ISO 15380

Δp - Q Performance curves

(measured at t = 50 °C and ν = 32 mm²/s)

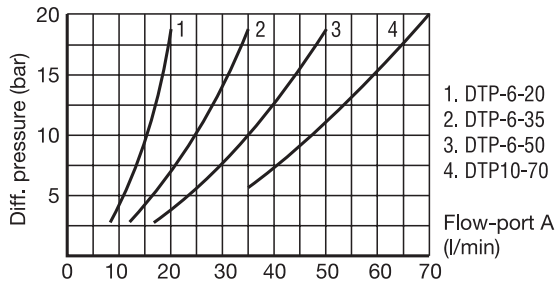

Dimensions (mm)

DTP-6

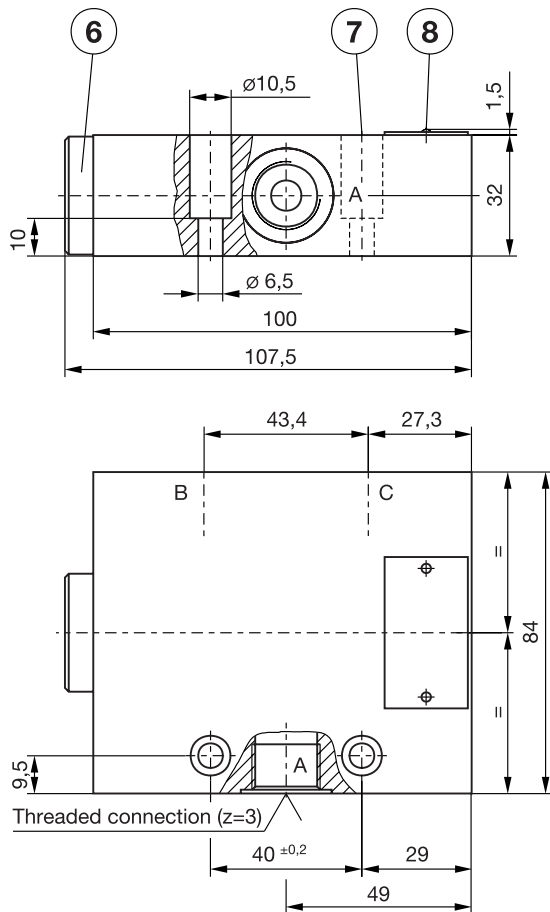

DTP-10

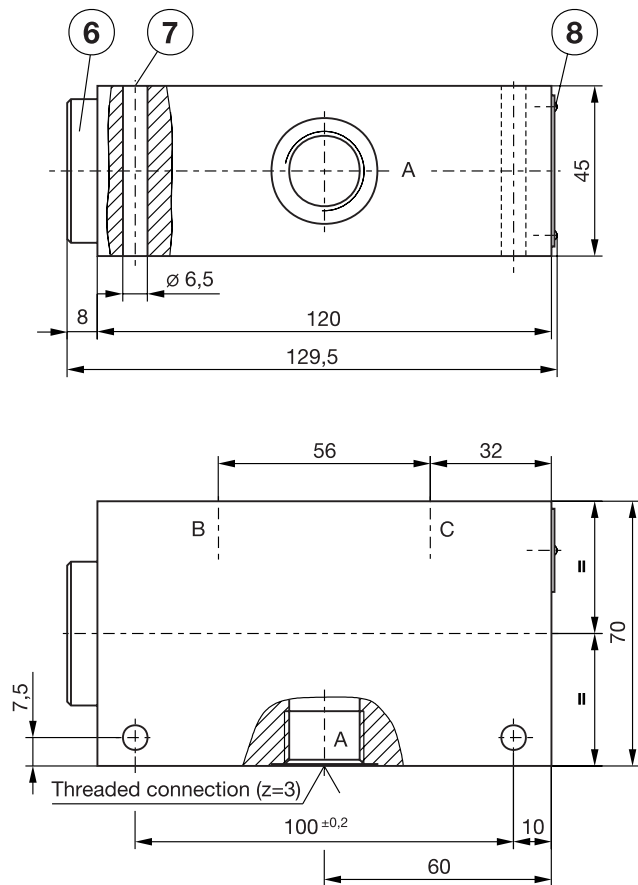

- 6. Valve cap
- 7. Two fixing holes for screws ISO 4762
 DTP-6 = M6x20-10,9
 DTP-10 = M6x55-10,9
 Tightening torque Md = max. 15 Nm
- 8. Nameplate